

MASTERFLEX™ 900

Re-Injectable hose for watertight construction joints in concrete

Description

MASTERFLEX 900 is an advanced injection hose system that is tough, flexible and resilient, made of chemically inert polymer for installation in construction joints. It enables injection of joints for watertightness, any number of times during the life of structure. It is unaffected by low temperature and immersion in water.

Uses

MASTERFLEX 900 is recommended for structures, whose construction joints must be watertight such as,:

- Water retaining structures
- Tunnels and basements
- Bridge decks, jetties
- Swimming pools.

Note: MASTERFLEX 900 is not recommended for expansion joints and in areas prone to significant settlements.

Advantages

- Allows pressure testing of joints for leaks.
- It is re-injectable whenever needed.
- Solid core that withstands concrete pressure.
- Chemically inert
- Flexible – can bend at corners

Typical Properties

MASTERFLEX 900 is available in two types:

	Type 1	Type 2
Outside diameter	19mm	24mm
Longitudinal injection hole diameter	6mm	10mm
Discharge opening diameter	3mm	5mm

Specification Clause

All construction joints shall be installed with MASTERFLEX 900, re-injectable hose specially designed with circular cross-section and containing neoprene seals on the openings which ensures one way flow of injection resin from inside out. The hose must be design to demonstrate re-injection capabilities at site. The Manufacturer shall provide all accessories required for end terminations and vacuuming arrangements for maintaining re-injection capabilities.

Directions for use

Refer to Figure 1 for details of construction of MASTERFLEX 900.

Surface Preparation

Joint surface must be clean and smooth. Repair honeycombs close to the joint using EMACO S88C T. Clean surface of loose materials such as, stones, dust, etc.

Hose fabrication for the joint

Fabricate MASTERFLEX 900 hose in lengths of max. 12m depending on the structure. Attach approximately 400mm lengths of vent hose to both ends of MASTERFLEX 900 hose and cover the junctions with a heat shrinkable plastic sleeve.

Figure 1: Construction of Masterflex 900

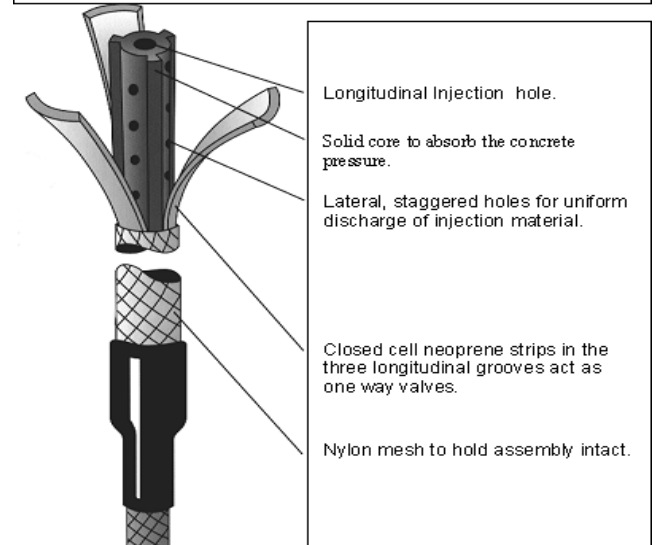
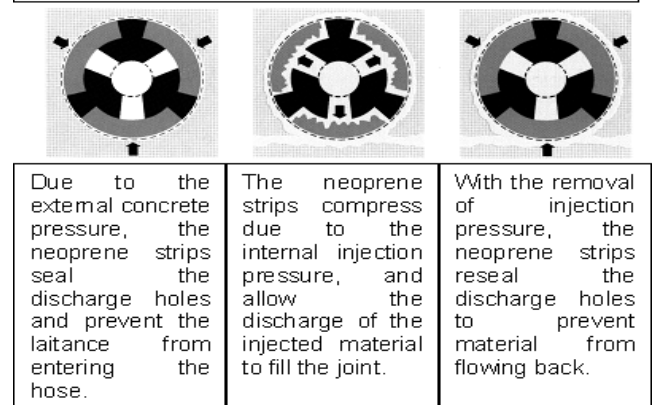

Figure 2: Action of neoprene 'one-way' valves



The vent serves as an injection (or exit) port and hence does not have discharge holes. The different colours (green and clear) of the vent hoses are to identify the input and exhaust ends.

Placing

Place MASTERFLEX 900 (Fig 3) along the middle of the joint face. In very thick sections, position the hose approximately 200-300mm from the water entry side. Clamp the hose firmly ensuring good contact with the surface using MASTERFLEX 900 Clips (Fig 4), which are fastened 250mm apart in 6mm dia, 50mm deep holes. Do not fasten the hose to reinforcement bars.

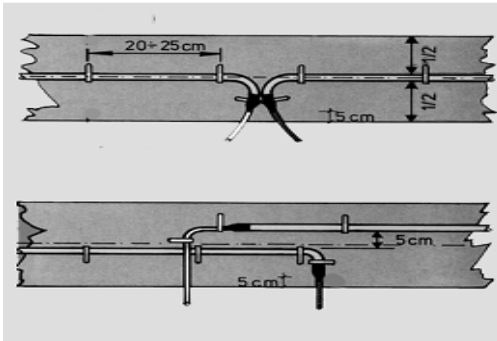
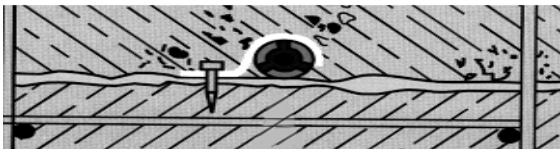
Figure 3: Installation**Figure 4: Clamping of hose**

Protect the installed hose from oil, dirt, concrete splatter and mechanical damage until placing of next lift of concrete. Ensure that at least 50mm of the vent hose is encased in minimum 50mm concrete with the vent ends visible outside after pouring the concrete.

Injection

After completion of curing freshly placed concrete, test the joint for watertightness by injecting water through the hose. If leakage is observed, injection of joint becomes necessary. To inject joints earlier, contact your BASF representative for advice.

Use one of the following products for injection depending on the nature and needs of the job.

- MASTERFLEX 801 (hydro-swelling vinyl ester metha-acrylate resin based)
- RHEOCEM 650/ RHEOCEM 800/ RHEOCEM 900 (micro fine cements).
- CONGRESIVE 1315 (Epoxy system).
- CONGRESIVE 1320 (PU system)

Note: Refer separate data sheets for each.

Starting from one end, inject the joints completely. Fill the hose with the injection material using an injection pump until it flows out of the other vent and plug that end with the 'End cap'. Pressurise to at least 2 bars and continue pumping while material is being consumed. When the pressure stabilises increase it to 20 bars and hold for 5 minutes. If no pressure drop is noticed, stop injection.

Repeat the procedure from the other end of the hose to ensure a similar pressure distribution over the whole length of joint.

Use MASTERSEAL 505 (see separate data sheet) to stop any material exuding from the wall surface or the joint.

Immediately after injection, clean the hose of leftover material by vacuuming and flushing with water. The hose is now ready for re-injection if it is required.

Packaging

MASTERFLEX 900 is available in 200 metres pack.

Storage

Store under cover, out of direct sunlight and protect from extremes of temperature. In tropical climates the product must be stored in an air-conditioned environment.

Failure to comply with the recommended storage conditions may result in premature deterioration of the product or packaging. For specific storage advice please consult BASF's Technical Services Department.

Safety precautions

As with all chemical products, care should be taken during use and storage to avoid contact with eyes, mouth, skin and foodstuffs (which can also be tainted with vapour until product fully cured or dried). Treat splashes to eyes and skin immediately. If accidentally ingested, seek immediate medical attention. Keep away from children and animals. Reseal containers after use. Do not reuse containers for storage of consumable item. For further information refer to the material safety data sheet. MSDS available on demand or on BASF construction chemicals web site.

Note

All BASF Technical Data Sheets are updated on regular basis; it is the user's responsibility, to obtain the most recent issue.

Field services where provided, does not constitute supervisory responsibility, for additional information contact your local BASF representative.

Disclaimer

Whilst any information contained herein is true, accurate and represents our best knowledge and experience, no warranty is given or implied with any recommendations made by us, our representatives or distributors, as the conditions of use and the competence of any labour involved in the application are beyond our control.

TDS Ref. no.: Mfxxx900/02/1206

BASF India Limited

Construction Chemicals Division

Plot No.37, Chandivali Farm Road, Chandivali ,Andheri(East)

Mumbai – 400072 India

Tel: +91 22 28580200, Fax: +91 22 28478381

e-mail: basfcc@vsnl.net www.basf-cc.co.in